

# CHRIS WITOR.com

## Subframe Variations

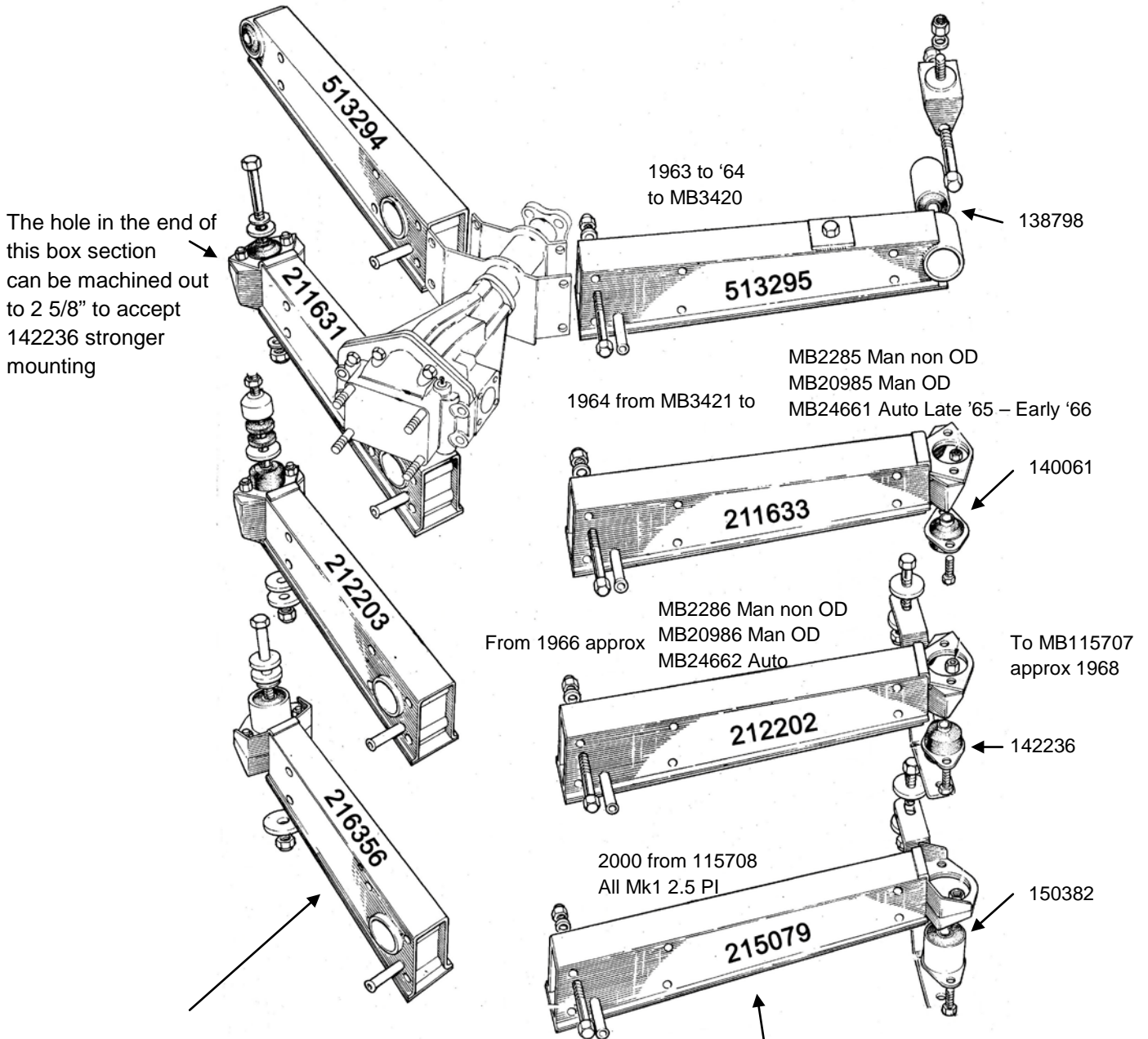

As Mk2  
 Except Mk2 uses box section 216356 with improved exhaust mount.

Stag similar to Mk2 except box section 215159 uses relocated hand brake cable tube.

Stag anti vibration straps also differ

As Mk2  
 Stag similar except 215160 uses additional exhaust hole & relocated handbrake cable tube.